

BOLLFILTER Automatic Type 6.04

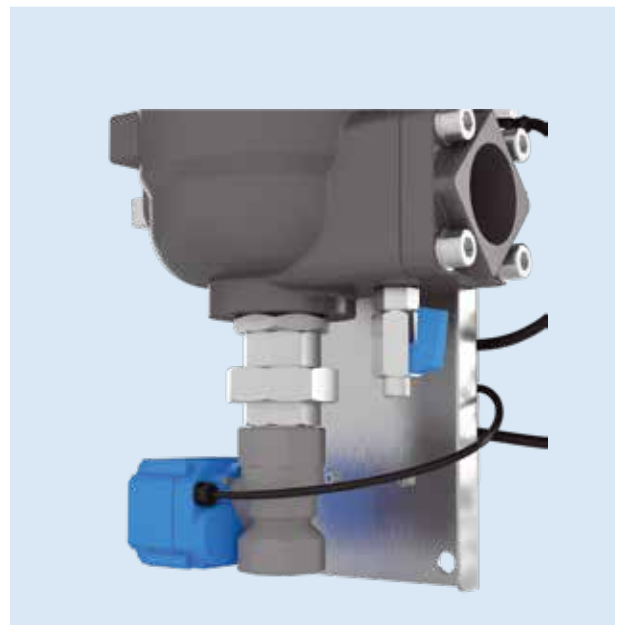

Fully automated protection by liquid filtration



Better performance, less maintenance: The technical edge with precise filtration and fully automated cleaning

Numerous industrial applications for machine and plant systems requiring nozzle protection, such as spray or sprinkler irrigation systems, require a high-performance, proven reversible flow filter concept which works at the highest technical level. For example, the pre-cleaning of feed water enables protection of sensitive nozzles or valves against rapid blocking and unnecessary wear. Robust and efficient, providing good value for money, the fully automated protective filtration of the new BOLLFILTER Automatic Type 6.04 delivers exactly this. The proven, high-quality BOLLFILTERs have remained a guarantee for reliability and precision mechanical engineering for

several decades now. This filter ensures that the required level of filtration is maintained to ensure your systems are clean thus retaining their high performance longer. The installation of this filter helps to reduce maintenance work considerably and the consequential time saving can substantially lower costs for your plant. As a result of our high level of investment in series manufacturing we are able to offer this precision engineered optimum performance filter at a very competitive price level.

Ideal for the filtration of the following liquids:

- machine cooling water
- cooling lubricants
- domestic water
- irrigation water
- turbine sealing water
- effluent
- spray water
- washing water
- cleaning water
- district heating water
- industry water and process water

The solution simply convinces

Speedy supply – even faster installation. The “plug & play” solution used by the BOLLFILTER Automatic Type 6.04 is immediately operational as a full module including the electronic control unit. Our global logistics ensures that you need not wait long for your filter.

The innovative filter concept “Made in Germany”

- High quality that is user friendly
- Compact robust and ready to use
- Low investment with high returns



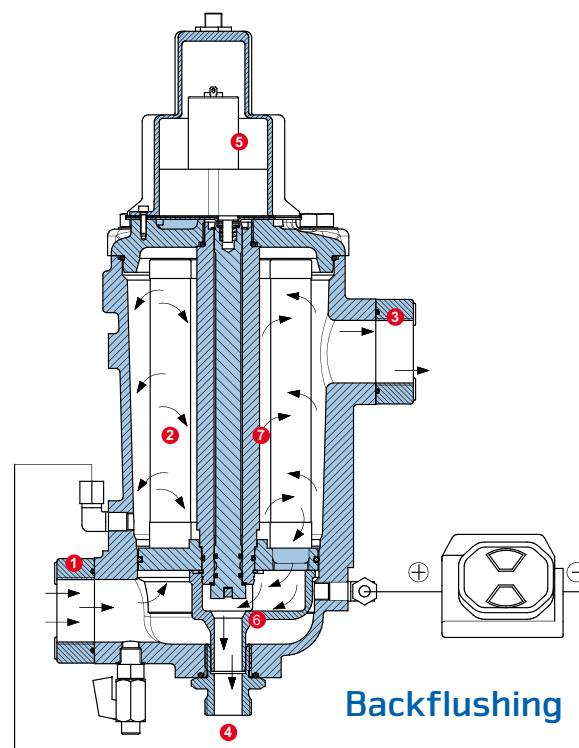
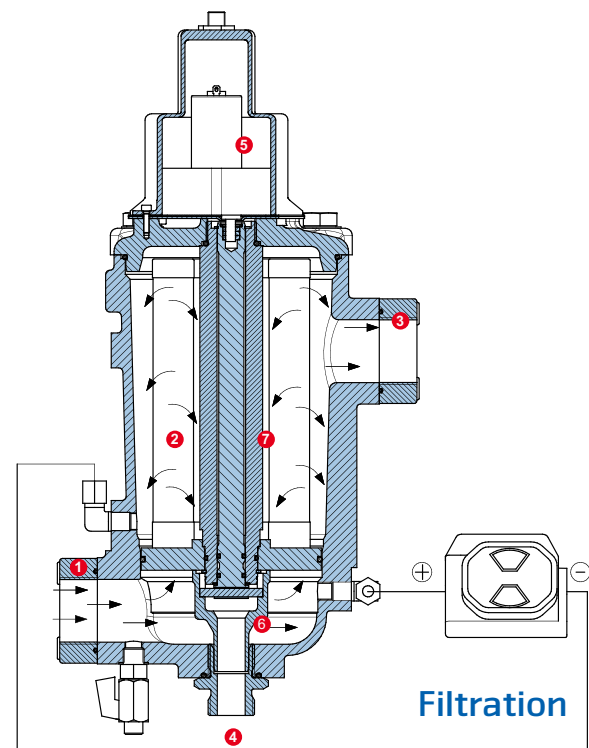

User friendly: Easy handling of the BOLLFILTER Automatic Type 6.04

The filter is designed with few components to guarantee easy access to the internal backwash unit with minimum wearing parts so minimal maintenance. All pressurised components, body and cover are manufactured from aluminium, all internal components from stainless steel and high-performance plastic.

Disassembly of the backwash unit is easily undertaken so enables simple efficient upkeep of the filter.



Control and monitoring

The BOLLFILTER Automatic is equipped with a fitted electronic control system.

- LED display for operation, backwashing and status
- Protection category: IP65
- Version 1 is fully pre-wired requiring only mains supply and signal cable connection

How the new series filter works

The liquid to be filtered flows from the inlet flange 1. into the filter housing and into the open end of 8 filter-cartridges 2. The liquid flows through the filter-cartridges from the inside to the outside and the particles in the liquid are held back by the filtration media in the filter-cartridges. The cleaned liquid then flows to the filter outlet 3.

The backwash release valve 4 is closed. The drive motor 5 is switched off. The dirt particles retained by the filter-cartridges generate an increasing differential pressure between the filter inlet and outlet. When the differential pressure reaches a certain value, the control unit triggers backwashing by switching

on the drive motor that rotates the backwash collector 6 past the individual filter-cartridges.

Simultaneously the backwash release valve is opened, resulting in a high axial flow in the filter-cartridge and the retained dirt particles are backwashed and ejected from the filter via pipe 7. After approx. two rotations of the backwashing device, the control unit switches the drive motor off. The backwash release valve is closed and the filter is clean. By sequentially backwashing each of the 8 individual filter-cartridges, the full forward flow volume is maintained during the regeneration phase.



Backwash unit showing filter element with mesh type filter-cartridge



Backwash unit showing filter element with longitudinal profile for special applications

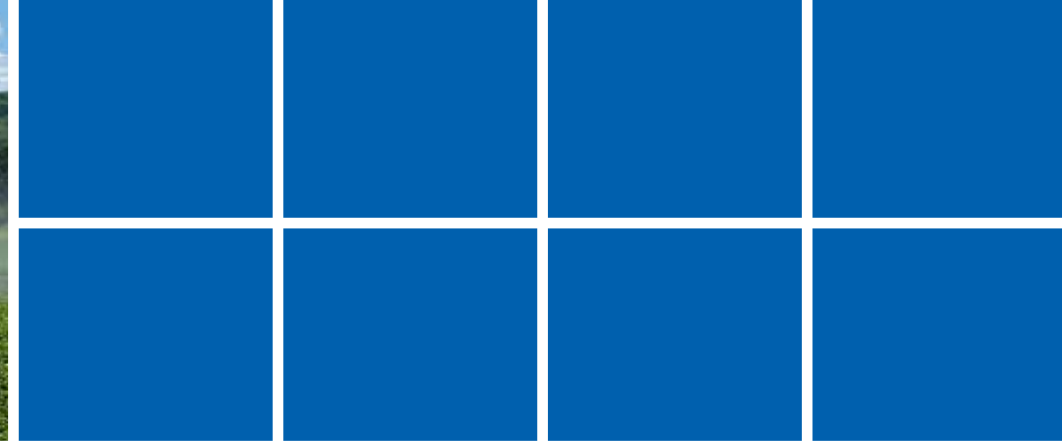

Overview of data and facts

Areas of use	Filtration of water, cooling lubricants and other low-viscosity fluids
Max. flow volume	18 m ³ /h or 300 l/min
Filter fineness	20 µm – 500 µm (dependent on filter-cartridge type)
Operating pressure	max. 16 bar
Operating temperature	0°C – 90°C
Pressurised components	Cover and casing hard-coated aluminium
Internal parts	Stainless steel/plastic
Filter element	8 screw-in cartridges with 1,200 cm ² filter area
Filter-cartridges	Stainless steel
Volume	3.5 l
Nominal width	DN 40 or G 1 ½
Operating voltage	24 V DC
Optional accessories	Power supply 230 V AC



Version 1



Version 2



Version 3

The variable, adaptable filter concept, specifically for use in mechanical processing machines and systems for the automotive and machine tool industries can be supplied in three different versions: Version 1: with electronic control unit and backwash release valve; Version 2: without electronic control unit, with backwash release valve; Version 3: without electronic control unit, without backwash release valve

Pressure loss curve for Type 6.04

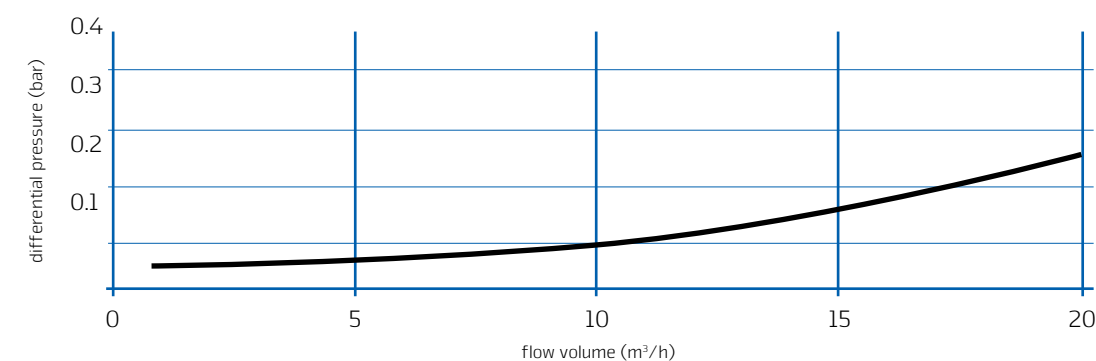

Your partner for success

For over 65 years, BOLL & KIRCH has been successful in developing ideas into products that have become established worldwide. As a specialist for liquid and gas filtration technology and the market leader for filtration in the shipbuilding and propulsion segment, the BOLLFILTER brand is world renown

as a leader for innovative filtration technology. Because of this we are able to expand our product range into a series of new industries and applications. This enables us to offer high quality products in cost-sensitive segments at attractive pricing levels.



BOLL & KIRCH Filterbau GmbH

Postfach 14 20 • 50143 Kerpen • Germany

Siemensstraße 10-14 • D-50170 Kerpen • Germany

Tel.: +49 2273 562-0

Fax: +49 2273 562-223

E-Mail: info@bollfilter.de

Internet: www.bollfilter.com